

Depths starting from only 80mm, the Micro Canal is one of the **shallowest** trench heating systems in the world. Designed for use with **eco-friendly** heating systems

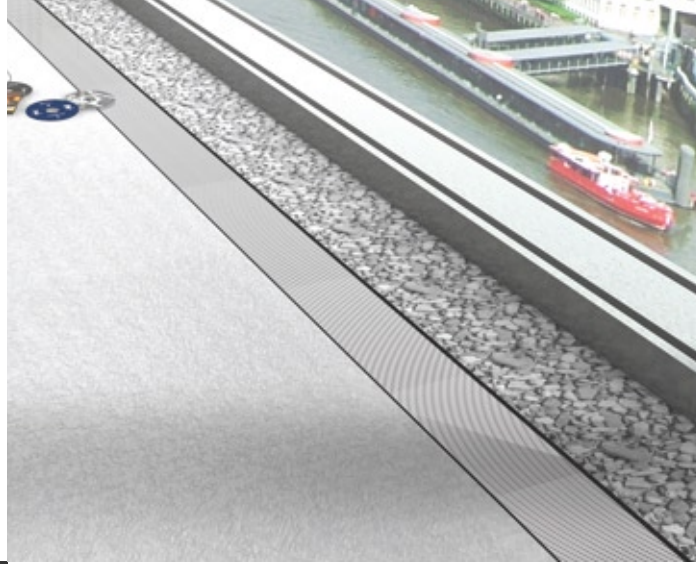

A compact, fan assisted trench heating system. Perfect for use in:

- Offices
- Retail
- Sustainability projects
- Any situation where duct height is limited

It may be modest in dimensions, but it boasts **high output**

Low-voltage DC-controlled technology improves airflow and provides a powerful output. This gives the Micro Canal full **compatibility** with low flow temperature systems, such as **heat pumps**

Stylish contemporary stainless steel grille

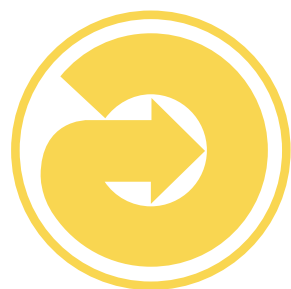

jaga



MICRO CANAL

maximum heat, minimum depth

Micro Canal

Outputs

Outputs in watts at 75/65/20°C, calculated in accordance with EN442



Depth ▼	Width ▼	Length ▶				
		600	950	1300	1650	2000
60	130	410	820	1230	1640	2050

All dimensions in millimetres.

Acoustic Data

Length ▶	600	950	1300	1650	2000
Sound pressure db(A)	18	21	22.8	24	25

These are typical values. For more detailed sound figures please contact Jaga.

Correction Factor Equations

Equation to determine the mean water temperature difference, minus ambient air (ΔT)

Equation to determine water mass flow rate (m)

T_F = Water flow temperature °C
 T_R = Water flow return temperature °C
 amb = Ambient temperature °C

Q = Total heat emitted by unit (kW)
 m = Water mass flow rate (kg/s)
 C_p = Specific heat capacity (4.187 kJ/kg °C) Approximate

$$\text{Equation 1: } \Delta T = \frac{T_F + T_R}{2} - \text{amb}$$

$$\text{Equation 2: } m = \frac{Q}{(T_F - T_R) \times C_p}$$

Micro Canal

Grilles

As this is a dynamic product, outputs are not affected by grille finish



Stainless steel

Correction Factors

Outputs at 75/65/20°C, average correction factors calculated in accordance with EN442

T _F ▼	T _L ▼	T _R ▶	30	35	40	45	50	55	60	65	70
80	20		0.70	0.75	0.80	0.85	0.90	0.95	1.00	1.05	1.10
	24		0.62	0.67	0.72	0.77	0.82	0.87	0.92	0.97	1.02
75	20		0.65	0.70	0.75	0.80	0.85	0.90	0.95	1.00	1.05
	24		0.57	0.62	0.67	0.72	0.77	0.82	0.87	0.92	0.95
70	20		0.60	0.65	0.70	0.75	0.80	0.85	0.90	0.95	
	24		0.52	0.57	0.62	0.67	0.72	0.77	0.82	0.87	
65	20		0.55	0.60	0.65	0.70	0.75	0.80	0.85		
	24		0.47	0.52	0.57	0.62	0.67	0.72	0.77		
60	20		0.50	0.55	0.60	0.65	0.70	0.75			
	24		0.42	0.47	0.52	0.57	0.62	0.67			
55	20		0.45	0.50	0.55	0.60	0.65				
	24		0.37	0.42	0.47	0.52	0.57				
50	20		0.40	0.45	0.50	0.55					
	24		0.32	0.37	0.42	0.47					
45	20		0.35	0.40	0.45						
	24		0.27	0.32	0.37						
40	20		0.30	0.35							
	24		0.22	0.27							



KEY
 T_F = Flow temperature °C
 T_R = Return temperature °C
 T_L = Desired air temperature °C

The indicated outputs ΔT 50 °C are the exact outputs, and are calculated in accordance with EN 442. An average correction factor is given in this table for outputs at other ΔT and is applicable for all dimensions. For comprehensive correction factors table see page 83.

Micro Canal

Connectors
Flexible stainless steel
connectors

Fan unit
Tangential fan

Inner casing
With height adjustment

Grille
Continuous stainless steel grille

Heat exchanger

Adjustable
Height adjustable as standard

Outer casing
With height adjustment

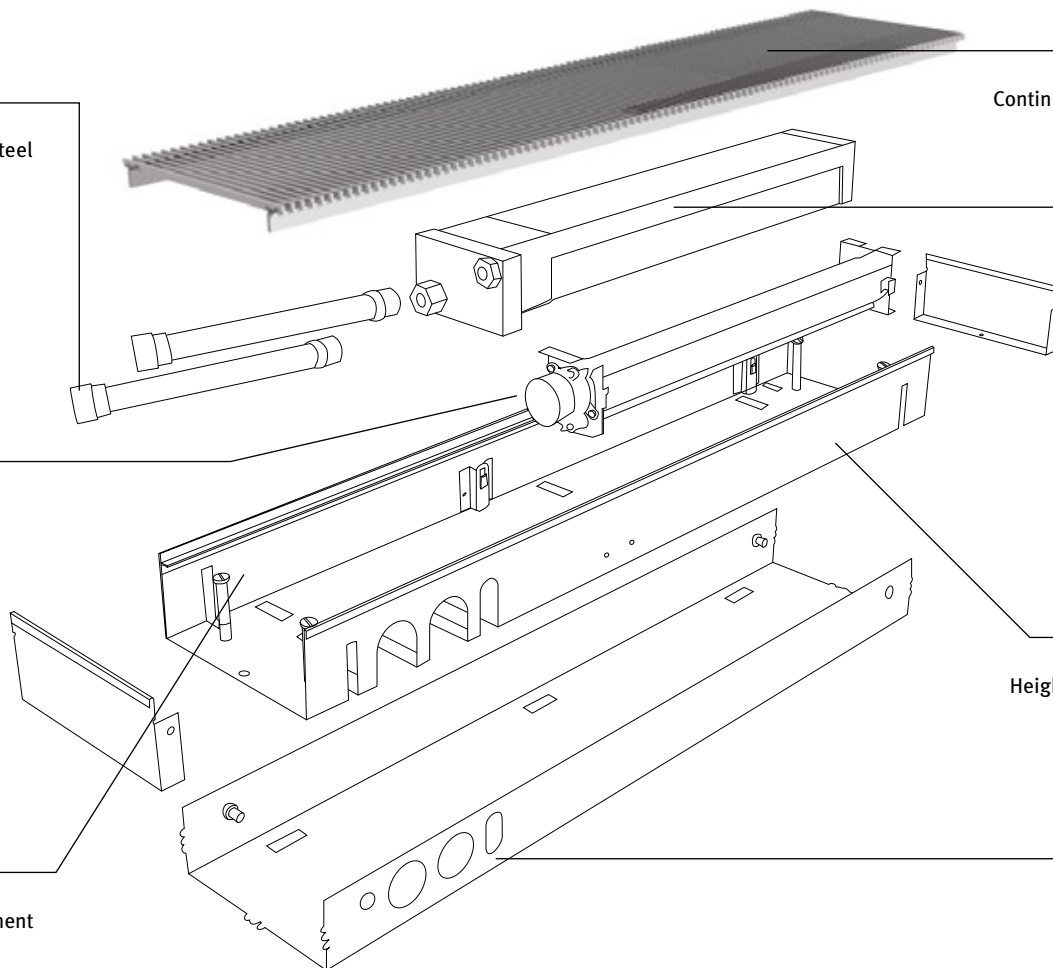

Control

- Automatic control
- Automatic on/off
- Supply 24 volts DC

Options

- Standard assembly/protection block
- Adjustable feet
 - 50mm - 80mm
 - 80mm - 130mm
 - 130mm - 230mm
 - 200mm - 370mm

Duct:

Shall be pre-mounted outer and inner ducts in Sendzimir galvanized steel plate of 1mm thick, complete with intermediate support brackets. This will be provided with anthracite grey epoxy polyester finish, RAL 7024 - gloss degree 10%. The inner duct shall provide overall height adjustment of the trench by means of adjustable feet and fixings. Specified lengths will comprise of suitable unitary lengths of up to 2000mm. Where longer lengths are required, separate units will be joined to form continuous lengths to suit site requirements.

The duct is to be complete with 4No. pre-perforated holes for pipework and electrical accommodation.

The trench is to be of sufficient quality to be provided with the manufacturer's 2 year guarantee.

Heat Exchanger:

Shall be manufactured from seamless copper tubes, fitted with aluminium fins. The fins shall provide high contact area to the tubes, guaranteeing optimum efficiency, across a wide range of flow & return water temperatures. The heat exchanger shall be complete with 2No. Brass 1/2" BSP connections. Generally these shall be same end connections and be suitable for left-hand installation. The exchanger shall be complete with 2No. stainless steel flexible connections to facilitate easy installation and cleaning of the completed unit.

The complete heat exchanger assembly shall be non corrosive and the whole assembly shall be electro statically lacquered with dirt repellent and dust proof anthracite grey epoxy polyester lacquer RAL 7024- gloss degree 70%.

The heat exchanger shall be supplied complete with 1/8" BSP air vent & 1/2" BSP drain cock, and the whole assembly to be pressure tested to 20 bar, with a maximum working pressure of 10 bar. The element shall be of sufficient quality to be provided with the manufacturer's 2 year guarantee.

Frame:

The frame shall be constructed from reinforced L-profile, Stainless Steel AISI 316, with a height of 4.7mm.

The frame shall be pre mounted on the micro floor duct.

The frame shall be supplied to the specified finish and colour.

The frame shall be of sufficient quality to be provided with the manufacturer's 10 year guarantee.

Fan Unit:

The unit shall be complete with one or more tangential fan activators. The units shall be powered by a 12 volt DC electrical supply, and be capable of on/off control via a surface contact temperature sensor monitoring water temperature.

Grilles:

Grilles shall be of the specified material and finish, and to the relevant specification as follows:

Rigid Stainless Steel Grille:

Shall be constructed from AISI 316 stainless steel, triangular profiled slats placed crossways 4.5mm x 2.2mm, with 6mm space between centres. The slats shall be interconnected by two lengthways supporting slats, and be so constructed as to have a free air flow of not less than 70%

Note:

Each measured trench duct supplied, shall come complete with factory pressure tested heat exchanger, grille, frame and height adjusters, ready to install.